

dimension®

BST 768, SST 768, & Dimension Elite User Guide



Notice

The information in this document is subject to change without notice.

STRATASYS, INC. MAKES NO WARRANTY OF ANY KIND WITH REGARD TO THIS MATERIAL, INCLUDING, BUT NOT LIMITED TO, THE IMPLIED WARRANTIES OF MERCHANTABILITY AND FITNESS FOR A PARTICULAR PURPOSE. Stratasy, Inc. shall not be liable for errors contained herein or for incidental or consequential damages in connection with the furnishing, performance, or use of this material.

This equipment has been tested and found to comply with the limits for a Class A digital device, pursuant to part 15 of the FCC Rules. These limits are designed to provide reasonable protection against harmful interference when the equipment is operated in a commercial environment. This equipment generates, uses and can radiate radio frequency energy and, if not installed and used in accordance with the instruction manual, may cause harmful interference to radio communications. Operation of this equipment in a residential area is likely to cause harmful interference in which case the user will be required to correct the interference at his own expense.

Changes or modifications to the Dimension system not expressly approved by Stratasy, the party responsible for compliance, could void the user's authority for use.

This document is protected by copyright. All rights reserved. Its use, disclosure, and possession are restricted by an agreement with Stratasy per software copyright. No part of this document may be photocopied, reproduced or translated into another language without the prior written consent of Stratasy, Inc. Printed in the USA.

Stratasy, Dimension, and Catalyst are registered trademarks of Stratasy, Inc. Krytox, Windows 2000, and Windows XP are registered trademarks of their respective companies.

© Copyright 2007 Stratasy, Incorporated.

March 2007



The Dimension system conforms with the following standards, in accordance with the EU Machinery, Low Voltage and Electromagnetic Compatibility Directives: EU 89/392/EEC, EU 98/37/EEC, EU 73/23/EEC amended by 93/68/EEC, EU 89/336/EEC

Introduction

Dimension is designed with ultimate simplicity in mind. The system enables you to build parts quickly, even if you have never used a 3D printer before. Its display panel prompts you to press a few keys to get you modeling quickly.

The system models with ABS plastic, so modeled parts are strong and durable. ABS also ensures that you will be able to drill, tap, sand, and paint your creations. With the speed and convenience of Breakaway Support Technology (BST 768) or Soluble Support Technology (SST 768 and Elite), completed parts are quickly available for review and test.

Dimension is an innovative combination of proprietary hardware, software, and material technology.

Congratulations...

you made a smart choice!

How To Use This Manual

This User's Guide is laid out in easy to follow sections which cover Set-up, Operation, Maintenance, and Troubleshooting of your Dimension printer. Be sure to read each section carefully so that you will get the best performance from your system.

Highlighted Information

The manual is written in a step-by-step format so as to guide you through a variety of operational tasks. Information of particular importance is presented in one of three formats

WARNING



A **WARNING** indicates a procedure that may cause Injury to an operator if the procedure is not followed. A **WARNING** will precede the paragraph of instruction to which it relates.

CAUTION



A **CAUTION** indicates a procedure that may cause Damage To Equipment if the procedure is not followed. A **CAUTION** will precede the paragraph of instruction to which it relates.

NOTE

A **NOTE** is used to highlight a specific point or to provide an operational tip. While useful, a **NOTE** does not indicate a procedure that can cause injury or damage if it is not followed. A **NOTE** will follow the paragraph of instruction to which it relates.

The Dimension printer guides you through operational tasks from a User Interface (UI) on the front panel of the printer. Throughout the User Guide, text representing messages that appear on the UI are presented in a specific format. **Interface Messages** appear as a bold, serif, fixed-pitch (mono-space) font.

Sections Of The Manual

Overview...

Provides a quick reference for the layout of the printer and its operating components. Overview also provides a quick reference for sources of additional information and printer supplies.

Setup...

Guides you through the initial printer installation and setup. Topics include unpacking, connecting power, installing software, and connecting to a computer network. Generally, topics in setup are only accomplished during installation or relocation of the printer.

Operation...

Further develops your understanding of the printer by presenting the User Interface, Loading and Unloading of Material, Building Parts, Removing Completed Parts, and Removing Support Material. The tasks presented are common procedures accomplished during the normal operation of the printer.

Maintenance...

Lists several tasks that you will need to perform to keep your printer performing at its best. Some tasks are 'As Needed' while others are determined by a set number of printer hours (CatalystEX includes an odometer of printer hours). 'House Cleaning', Axis Maintenance, Tip Cleaning Assembly Replacement, Chamber Lamp Replacement, and Tip Shroud Replacement are procedures that you can perform with the help of the User Guide.

Troubleshooting..

Allows you to perform some problem diagnosis and correction procedures in the event that your printer has a problem. A Troubleshooting Checklist, Fault Determination Codes, and a procedure to recover from a Loss of Extrusion are provided.

Table of Contents

Introduction	3
<i>How To Use This Manual</i>	4
<i>Highlighted Information</i>	4
<i>Sections Of The Manual</i>	5
Overview	11
<i>Finding More Information</i>	14
<i>Setting up Dimension</i>	14
<i>Using Dimension</i>	14
<i>Supplies</i>	15
Setup	17
<i>Workspace</i>	17
<i>Unpacking</i>	18
<i>Installing Forklift Access Covers</i>	20
<i>Power Connections</i>	20
<i>Powering On Dimension</i>	22
<i>Insert Modeling Base</i>	23
<i>Installing Software</i>	24
<i>Networking Your Printer</i>	25
<i>Connecting Directly To Your PC</i>	28
<i>Verifying Tip Depth</i>	30
Operation	33
<i>Display Panel and Keypad</i>	33
<i>Inserting a Modeling Base</i>	34
<i>Powering On Dimension</i>	34
<i>Powering Off Dimension</i>	35
<i>Cycling Power</i>	35
<i>Loading Material</i>	36

8 Table of Contents

<i>Unloading Material</i>	39
<i>Building a Test Part</i>	41
<i>Sending Your CAD File to the System</i>	41
<i>Building a Part from Your File</i>	43
<i>Chamber Lights</i>	43
<i>Pausing Build</i>	44
<i>Resuming Build from Pause Mode</i>	44
<i>Resuming Operations from Standby Mode</i>	44
<i>Canceling a Job</i>	45
<i>Removing a Completed Part</i>	45
<i>Removing Support Material</i>	46
<i>Breakaway Supports</i>	46
<i>Soluble Supports</i>	47
Maintenance	49
<i>Startup Kit Tools</i>	49
<i>After Each Build</i>	50
<i>Empty Purge Container</i>	50
500 Hour Maintenance	50
<i>Clean Fan Filter</i>	50
<i>Tip Cleaning Assembly (Brush/Flicker Assembly)</i>	51
2000 Hour Maintenance	52
<i>Axis Maintenance</i>	52
As Needed Maintenance	53
<i>Remove Debris Buildup</i>	53
<i>Vacuum Build Chamber</i>	53
<i>Clean Door Glass</i>	53
<i>Chamber Lamp Replacement</i>	54
<i>Tip Shroud Replacement - SST 768 and Elite Only</i>	55

Troubleshooting	59
<i>Troubleshooting Checklist.....</i>	<i>59</i>
<i>Fault Determination Codes</i>	<i>61</i>
<i>Loss of Extrusion.....</i>	<i>61</i>
<i>Diagnosing Loss of Extrusion.....</i>	<i>61</i>
<i>Recovering From Loss of Extrusion</i>	<i>62</i>

Overview

Dimension builds models, including internal features, from CAD STL files. The system builds three-dimensional parts by extruding a bead of ABS plastic through a computer-controlled extrusion head, producing high quality parts that are ready to use immediately after completion. With two layer resolution settings, you can choose to build a part quickly for design verification, or you can choose a finer setting for higher quality surface detail.

The Dimension family consists of three 3D printers. [Table 1](#) indicates the individual printer features.

Table 1: 3D Printer Features

Feature	BST 768	SST 768	Elite
.007 in. slice (.178 mm)			X
.010 in. slice (.254 mm)	X	X	X
.013 in. slice (.330 mm)	X	X	
P400 Model Material	X	X	
P430 Model Material			X
BST (Breakaway Support Material)	X		
SST (Soluble Support Material)		X	X

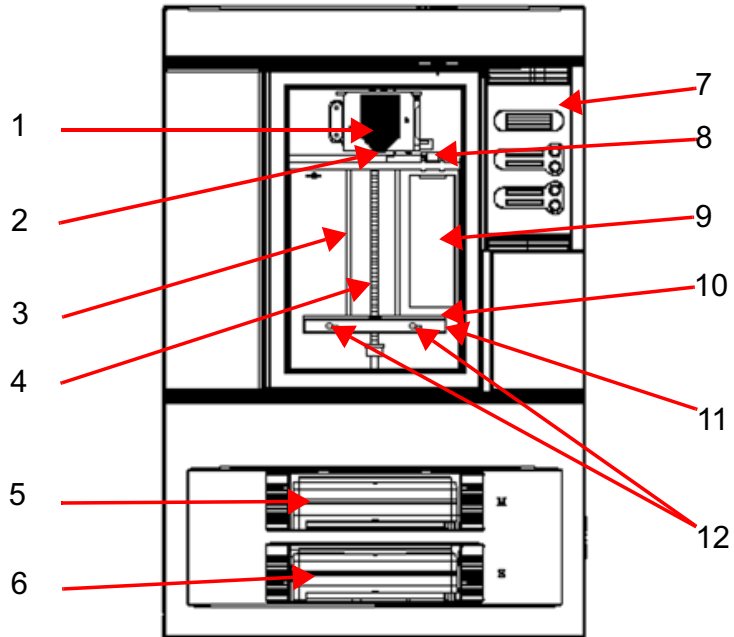

Figure 1: Dimension Front View

<u>Item</u>	<u>Nomenclature</u>	<u>Item</u>	<u>Nomenclature</u>
1	Extrusion Head	7	Display Panel
2	Extrusion Tips	8	Tip Cleaning Assembly
3	Guide Rods	9	Purge Container
4	Lead Screw	10	Modeling Base
5	Model Material Cartridge	11	Z Platform
6	Support Material Cartridge	12	Platform Retainers (2)

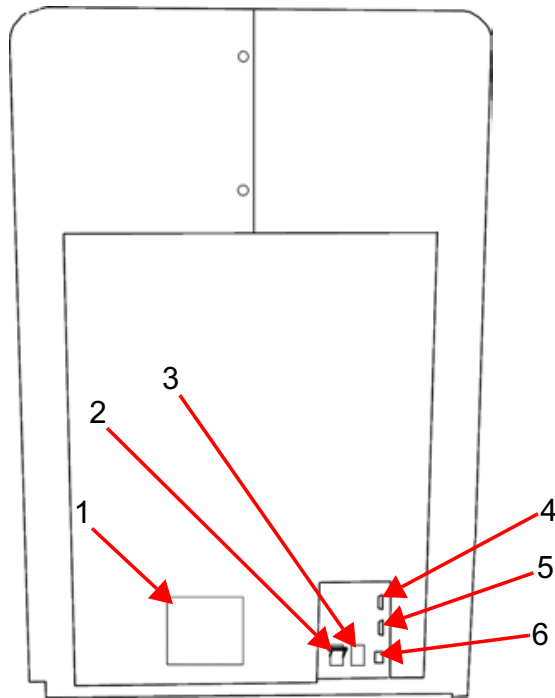

Figure 2: Dimension Rear View

Item Nomenclature

- 1 Fan Cover
- 2 Main Circuit Breaker
- 3 Power Cord Adapter

Item Nomenclature

- 4 UPS Connection
- 5 Diagnostic Hookup
- 6 Network Cable Connection

The Dimension system consists of two primary components — the Dimension 3D printer and CatalystEX. CatalystEX is the preprocessing software that runs on a Windows 2000 or Windows XP Pro platform.

Dimension's build envelope measures 203 x 203 x 305 mm (8 x 8 x 12 in). Each material cartridge contains 922 cc (56.3 cu. in.) of usable material — enough to build continuously for about four days without reloading.

Finding More Information

Several references are available for use with Dimension.

Setting up Dimension



Dimension User Guide

Step-by-step instructions for installing, setting up and operating the Dimension system.

Using Dimension



CatalystEX Online Help

Simple operating instructions for CatalystEX are available through the application. Help is displayed in the Dynamic Help window ...or... you can access them at from the Menu Bar - **Help>Contents**.



World Wide Web

Additional information is available at: <http://www.dimensionprinting.com>

Supplies

This section lists all replaceable supplies used by the Dimension modeling system. The parts mentioned in this list can be obtained by contacting the sales representative through whom you purchased your system.

Part Number	Description
Modeling Material - BST 768 and SST 768 Only	
340-20000	White ABS Filament Cartridge
340-20200	Black ABS Filament Cartridge
340-20300	Red ABS Filament Cartridge
340-20400	Blue ABS Filament Cartridge
340-20500	Green ABS Filament Cartridge
340-20600	Yellow ABS Filament Cartridge
340-20800	Steel Gray ABS Filament Cartridge
Modeling Material - Elite Only	
340-21200	Natural P430 ABS Filament Cartridge
Breakaway Support Material - BST 768 Only	
340-30000	Breakaway Support Cartridge
Soluble Support Material/Concentrate - SST 768 and Elite Only	
340-30200	Soluble Support Cartridge
300-00600	Soluble Soluble Concentrate (12 bottles)
Modeling Base	
340-00200	Modeling Base (qty. 24)
To order supplies for your Dimension system, contact your local Dimension reseller.	

Setup

Workspace

Observe the following when placing Dimension in its operating location:

- Dimension has an approximate weight of 128 kg (282 lbs.) and requires a table capable of safely supporting 136 kg (300 lbs).
- System Dimensions:
914 x 686 x 1041 mm (36 x 27 x 41 in)
Four-inch minimum space behind unit for air circulation
- Dedicated outlet requirements (Nominal):
100-120 VAC, 60 Hz, 15 A min. (20 amp recommended)
–or–
220-240 VAC, 50/60 Hz, 7 A min. (10 amp recommended)
- Temperature: 18–32°C (65-90°F)
- Relative Humidity: 30-80%, Non-condensing
- Ethernet 10/100 Base T network
- Network patch cable with RJ45 connectors
- Optional UPS for power interruptions (brown-out conditions):
Rated Power – 2200 VA
Output Power – 1600 watts

Unpacking

This section describes the recommended procedures for unpacking and preparing Dimension for its first use.

Unpack the printer:

WARNING



The Dimension printer weighs approximately 128 kg (282 lbs). Use proper moving and lifting techniques when positioning the unit. For your convenience, there are forklift pads built into the bottom of the unit. They are accessible from the side of the unit.

1. Before unpacking the printer, move it near to its operating location.
2. Remove the plastic banding from around the cardboard.
3. Remove the top cover. Set aside the fork access covers (2) and bag of screws (2).
4. Remove screws (4) that attach cardboard to pallet and remove the cardboard side panels.
5. Remove the top foam.
6. Remove outer plastic wrap - use care if using a knife so as to not scratch the printer.
7. Remove the foam door channels (2) and tape.

WARNING



The Lead Screw and Guide Rods are lubricated with a thin coat of Krytox grease. Krytox grease can cause skin irritation. Be careful not to get the grease on your hands or clothing.

CAUTION

Remove the foam tubes that isolate the extrusion head from the frame (see [Figure 3](#)). The printer will be damaged if powered on with the foam tubes in place.

CAUTION

Be careful not to damage the rod sensors when removing the foam tubes (see [Figure 3](#)).

8. Remove the foam tubes that isolate the extrusion head from the frame (see [Figure 3](#)).

Circles indicate Rod Sensor locations. There are also two sensors on the back side of the Extrusion Head.

Foam Tubes (4)

Extrusion Head (SST 768 & Elite Shown)

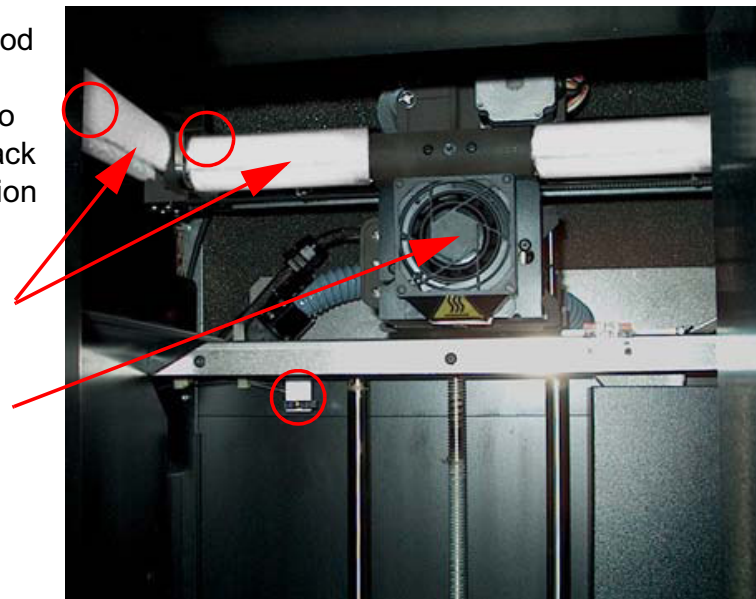

Figure 3: Foam tubes isolating the extrusion head from the Z-axis frame

9. After unpacking, inspect the printer and report any shipping damage to the carrier.

Installing Forklift Access Covers

The forklift access covers can be placed over the forklift channels after the printer is placed in its final location (see [Figure 4](#)). The covers are press-fit in the front and held in place with one screw in the rear.



Figure 4: Installing the forklift access covers

Power Connections

This section discusses the procedure for preparing all power connections for the printer.

CAUTION



Before connecting power to the printer, make sure that the Dimension circuit breaker is in the off (down) position. It is located in the rear of the printer next to the power cord attachment point.

Dimension is provided with two power cords: one for 110 V and one for 220 V.

Prepare all power connections:

1. Connect the male end of the supplied power cord directly into a grounded electrical outlet, as shown in [Figure 5 on page 21](#). (If using a Uninterrupted Power Supply (UPS), connect the cord directly into the UPS).

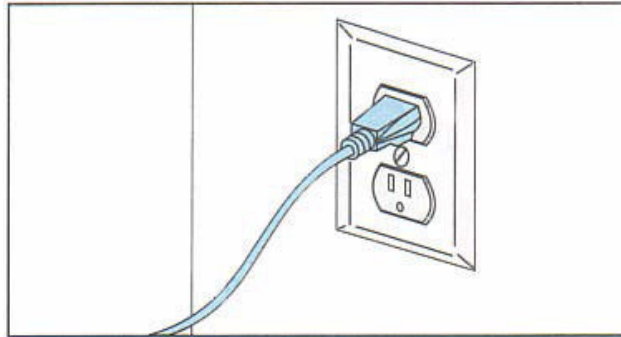

Figure 5: Connecting to a grounded electrical outlet



CAUTION

Do not use an extension cord or power strip with the Dimension system. Connect the cord directly into the receptacle or UPS.

2. Connect the female end of the power cord directly into the rear of the cabinet.
3. Switch the Dimension circuit breaker to the on (up) position. Power is now supplied to the Dimension system. The system is ready to be 'Powered ON'.

Powering On Dimension

WARNING



Dimension's build chamber and extrusion-head tip get very hot! The chamber and head tip reach temperatures of approximately 75° C (167° F) and 280° C (536° F) respectively. Personal injury can occur if proper techniques and safety materials are not used. Use the leather safety gloves provided in the Startup Kit when working inside the printer.

CAUTION



Remove the foam tubes that isolate the extrusion head from the frame (see [Figure 3 on page 19](#)). The printer will be damaged if powered on with the foam tubes in place.

Dimension's power switch is located on the right (viewed from the front) side cover of the cabinet, near the bottom front corner (see [Figure 6](#)). After the switch is pushed, Dimension boots up in three to seven minutes.



*Figure 6: Location of Power Switch
(View From Right Side of Printer)*

NOTE

If the printer was off and is at room temperature, it requires approximately 40 minutes to warm up before you can perform any functions. Temperatures are factory-preset and not adjustable. The panel displays the head and envelope temperatures while Dimension is warming up and cooling down.

NOTE

For safety, the head and Z Platform do not move while the chamber door is open. During warm-up and operation the door is locked. The door can be opened only when Dimension is not building a part, getting ready to build a part, or in Pause mode.

Insert Modeling Base

Make sure retainers are turned 'down' - so as not to interfere with the modeling base installation. Set the modeling base on the Z Platform aligning the tabs on the modeling base with the slots on the metal tray. Slide the modeling base toward the back of the unit until its front edge (with the handle) is flush with the front edge of the tray (see [Figure 7](#)). Secure the base with the two retainers by turning them up.

NOTE

When inserting and removing the modeling base, use the handle to avoid touching the top surface. Grease and oil that contact the top build surface could cause poor part adhesion. You can clean the build surface with isopropyl alcohol if necessary.

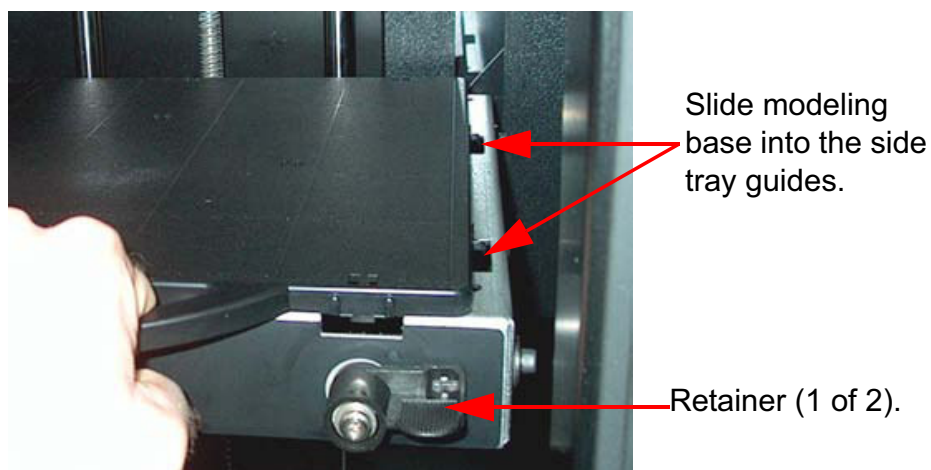

Figure 7: Inserting a modeling base

Installing Software

There are two software programs that work with Dimension.

- CatalystEX is the preprocessing software that controls Dimension. If you have not already done so, you will need to install the CatalystEX software on your PC. You will find the CatalystEX software on the CD-ROM included in your Startup Kit (See “Install CatalystEX:” on page 24.).
- There is also ‘controller’ software loaded directly onto your Dimension system from the factory. Because we do occasionally make changes to this software, you will need to verify that you have the latest version installed (See “Verifying controller software version:” on page 24.). A controller software CD is included in your Startup Kit.

Install CatalystEX:

1. Insert the CatalystEX installation disc into your CD-ROM drive. The installation menu automatically appears.
2. Click the **Install** button.
3. Follow the prompts to finish installing the software.

NOTE

CatalystEX’s installation setup allows you to change or confirm the target installation directory. To install CatalystEX in a directory other than the default, type the path and directory name in the dialog box when prompted.

4. If you want to customize your installation, select the **Custom** option. Custom options include the following:
 - CatalystEX Files
 - Training Files

Verifying controller software version:

5. Check the version displayed on the system keypad.
 - From **Idle**, press **Maintenance**. The version number will be listed in the top display window under **System Maintenance**.

6. Compare the version number to the controller software CD provided in the Startup Kit.
7. If the version on the controller software CD is newer than the system version, follow the Controller Software Upgrade Notice instructions provided in the Startup Kit.

Networking Your Printer

You will need to establish communication between your PC and printer before you can send files to print. How you establish this communication is dependent upon how your computer network is configured. In many cases, it is a simple matter of letting the CatalystEX software 'find' your printer. In some situations you may need to set the network address for your printer and, possibly, record the IP address in the CatalystEX program.

Establishing communication on a Dynamic network:

If you are on a Dynamic network (or not sure of your network type) follow these steps to allow the CatalystEX software to 'find' your printer and establish communication.

1. Plug in the network patch cable from your network to the rear of Dimension. (A 14 foot network cable (blue) is included with the Start Up Kit.)
2. Make sure the printer is 'on' and determine the Unique Device Name (UDN) for your printer.
 - A. From **Idle** (or **Ready to Build**), press **Maintenance**. The panel displays **System Maintenance** and the software version.
 - B. Press **Set Network**. The top window displays: **Network Admin - Dynamic IP Address; UDN**
 - C. The UDN for your printer is listed here. This is preset at the factory and cannot be changed.
3. From your PC, start the CatalystEX application.
 - A. From the General Tab, click the 'Manage 3D Printers' button.

- B. Click the 'Add from Network...' button in the lower right corner of the pop-up.
- C. A new pop-up, 'Add 3D Printer', should list your printer in the main window (identified by its UDN). Click on the printer in this window and enter a Name and Location (your choice) in the lower portion of the pop-up.
- D. Click 'Add Printer' - and you are ready to go. Close the 3D Printer pop-up.

NOTE

If your printer is not displayed in the 'Add 3D Printer' pop-up, you are not using a Dynamic network. You will need to set up a Static Network address.

If necessary, set the Static Network addresses:

1. Obtain your network addresses from your Network Administrator.
2. From **Idle** (or **Ready to Build**), press **Maintenance**. The panel displays **System Maintenance** and the software version.
3. Press **Set Network**. The top window displays: **Network Admin - Static IP Address; UDN**
4. Press **Static IP** to display current settings. For example::

IP Address: 192.000.000.001
NM Address: 255.255.000.000
GW Address: 198.000.000.001

These are the factory default addresses; they must be changed for your network.

5. Look for the cursor beneath the first digit of the IP address. The cursor does *not* blink. To update the IP address:

Press **Increment** to increase the value one digit at a time.

Press **Next Digit** to move the cursor one place to the right.

Press **Last Digit** to move the cursor one place to the left.

6. Use the three functions above to set your IP address.
7. After setting the final digit of the IP address, move the cursor one more place to the right. The cursor moves to the NM (or Netmask) address. Follow the same steps for setting the NM and GW addresses.
8. When you have finished setting the addresses, press **Done**. The panel displays `Change IP, Netmask, Gateway?`
9. Press **Yes**. The panel then displays `Resetting Network` and after a moment returns to `Idle` or starts warming up.
10. If you have not done so already, plug in the network patch cable from your network to the rear of Dimension.
11. From your PC, start the CatalystEX application.

NOTE

Detailed instructions for using CatalystEX can be found in the CatalystEX Help file.

- A. From the General Tab, click the 'Manage 3D Printers' button.
 - B. Click the 'Add from Network...' button in the lower right corner of the pop-up.
 - C. A new pop-up, 'Add 3D Printer', should list your printer in the main window (identified by its UDN). Click on the printer in this window and enter a Name and Location (your choice) in the lower portion of the pop-up.
 - D. Click 'Add Printer' - and you are ready to go. Close the 3D Printer pop-up.
12. If your printer is NOT displayed in the 'Add 3D Printer' pop-up (Step 11.C.), you will need to add the printer IP address manually.
 - A. From the General Tab, click the 'Manage 3D Printers' button.
 - B. Click the 'Add Manually...' button in the lower right corner of the pop-up.
 - C. In the pop-up, 'Add 3D Printer', enter a Name and Location (your choice) for your printer in the appropriate fields.

- D. Enter the IP Address for your printer in the appropriate field. It will be the same address as the one entered in Step 4.
 - E. Select the appropriate printer type from the drop down list.
 - F. Click 'Add Printer' and close the 3D Printer pop-up.
13. If you are unable to connect the printer to your PC, contact your Network Administrator.

Connecting Directly To Your PC

You can connect the Dimension printer directly to your PC without the use of a network. This is most easily accomplished with the printer in Dynamic network mode (as received from the factory).

1. Connect a crossover cable from your printer directly into a network port on your PC (A 14 foot crossover cable (orange) is included with the Start Up Kit.)
2. Make sure the printer is 'on' and determine the Unique Device Name (UDN) for your printer.
 - A. From **Idle** (or **Ready to Build**), press **Maintenance**. The panel displays **System Maintenance** and the software version.
 - B. Press **Set Network**. The top window displays: **Network Admin - Dynamic IP Address; UDN**
 - C. The UDN for your printer is listed here. This is preset at the factory preset and cannot be changed.
3. From your PC, start the CatalystEX application.

NOTE

Detailed instructions for using CatalystEX can be found in the CatalystEX Help file.

- A. From the General Tab, click the 'Manage 3D Printers' button.
- B. Click the 'Add from Network...' button in the lower right corner of the pop-up.

- C. A new pop-up, 'Add 3D Printer', should list your printer in the main window (identified by its UDN). Click on the printer in this window and enter a Name and Location (your choice) in the lower portion of the pop-up.

NOTE

It may take up to 1 minute for your printer to appear in the pop-up window.

- D. Click 'Add Printer' - and you are ready to go. Close the 3D Printer pop-up.
4. If your printer does not appear in the pop-up window:
- A. Cancel the 'Add 3D Printer' pop-up and click the 'Add Manually' button on the '3D Printers' pop-up.
 - B. In the pop-up, 'Add 3D Printer', enter a Name and Location (your choice) for your printer in the appropriate fields.
 - C. Enter the Dynamic IP Address for your printer (from Step [2B](#)) in the appropriate field.
 - D. Select the appropriate printer type from the drop down list.
 - E. Click 'Add Printer' and close the 3D Printer pop-up.
 - F. If you get an 'Error: Unable to connect to printer.' message it may be that your PC is not configured for Dynamic networking. To configure your PC for Dynamic networking:
 - i. From the 'Control Panel' of your PC, choose 'Network and Internet Connections'.
 - ii. Choose 'Network Connections', then double click 'Local Area Connection'.
 - iii. Scroll the 'Local Area Connection Properties' window to find the 'Internet Protocol' (TCP/IP) selection. Double click or highlight and click the 'Properties' button.
 - iv. From the 'General' Tab of the 'Internet Protocol TCP/IP' Properties pop-up click the 'Obtain an IP address automatically' radio button.
 - v. Click OK, then OK again.

- vi. After allowing your PC a minute or so to adjust to the new setting, your PC should connect to your printer.
- vii. If you are still unable to connect to your printer, recheck your connections and settings. Contact your local reseller for additional customer service.

Verifying Tip Depth

The system's tip depth has been set at the factory and normally does not need adjustment. During shipment, however, tip depth may shift. Customers that setup and install their own systems need to verify the tip depth setting prior to building. Building with the wrong tip depth can result in models not adhering to the modeling base or a loss of extrusion.

To verify tip depth:

1. Install an unused modeling base.
2. Load Model and Support material (see ["Loading Material" on page 36](#)).
3. Press **Maintenance**.
4. Press **Test Parts**, and select *test_tipdep_plstc.cmb*.

The printer will create six groups of numbers on the modeling platform. Each individual group will consist of four number pairs. Each number pair will have an extruded number and an etched number. Each number pair is created at one of four Z-heights: -5, 0, +5, and +10 (in .001 inches from 'home' level). See [Figure 8 on page 31](#).

NOTE

The etched number is created by the idle tip. It is normal for only some of these numbers to be visible.

The extruded number is created at a very low flow rate and may not show up clearly.

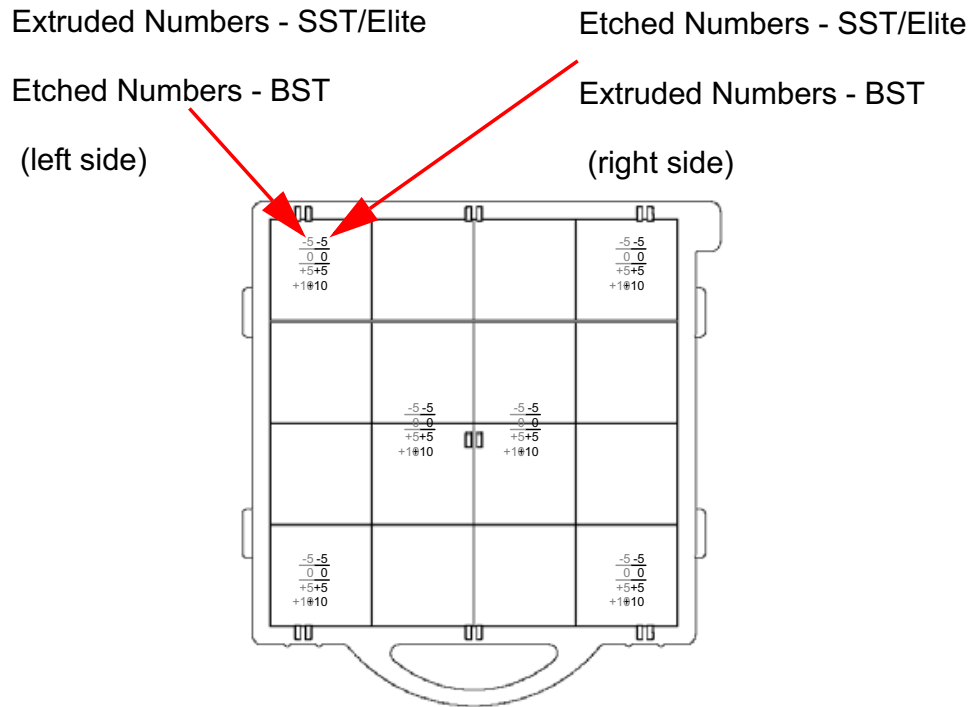

Figure 8: Modeling base with test_tipdep_plstc.cmb model

- Evaluate the **etched** numbers in each of the six groups. The etched numbers must meet the following criteria:
 - 5 must be visible in at least one of the six groups.
 - +10 must **not** be visible in any of the six groups.

NOTE

The etched numbers can be difficult to see. It may be necessary to tilt the modeling base to the light for inspection.

It is acceptable for some groups to have **NO** visible etched numbers. To meet the criteria, only one of the six groups must have a visible -5.

- If the tip depth does not meet the above criteria, run the model a second time on a second unused modeling base and evaluate again.
- If the tip depth again fails the above criteria, contact your Dimension service provider for more information on adjusting tip depth.

Operation

Display Panel and Keypad

The main User Interface to Dimension is the Display Panel and Keypad (see [Figure 9](#)).

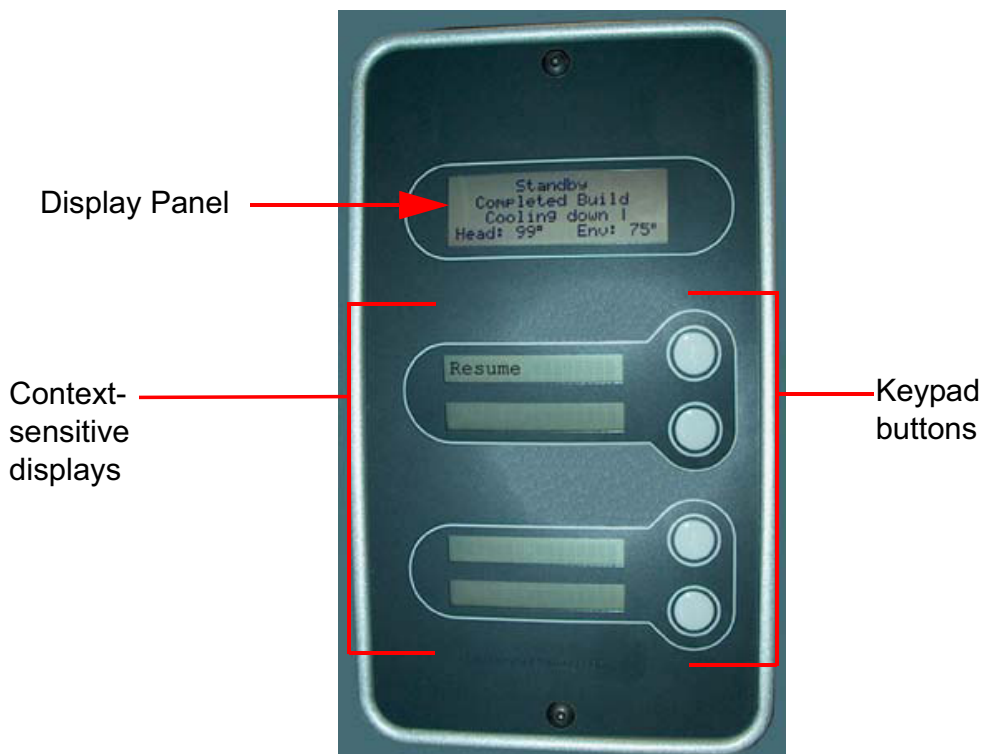

Figure 9: Dimension display panel and keypad

The Dimension display panel and keypad are very easy to use, consisting of a larger multiple-line LCD display on top, and four single-line context-sensitive displays, each with one button (or key). The top line in the large display always reveals the printer status. The lower three lines of the large display show details related to the current operation.

At times there will be an item blinking in the lower (context-sensitive) displays. The blinking item is usually the most logical selection.

Inserting a Modeling Base

Prior to inserting a modeling base into the tray, remove any material buildup on and behind the Z Platform and around the lead screw. Failure to do so could cause the modeling base to be unlevel or, if the amount of buildup is large enough, the Z Platform could jam at its upper limit.

Install the modeling base (See [“Insert Modeling Base”](#) on page 23. - "Setup").

Reusing a modeling base:

The square outlines on the modeling base represent modeling areas. The base is intended for single-use on each modeling area. Building on a used modeling area may cause loss of extrusion or cause a part to curl or break loose from the modeling base.

NOTE

Use CatalystEX (Pack Tab) to position a part on the modeling base.

CAUTION



Failure to completely remove all other layers from a previous build can cause a head collision and result in system damage.

Before inserting a used modeling base into the printer, make sure that all modeling and support materials are removed from the base.

A modeling base may become worn or distorted after several builds. The printer performs a modeling base levelness check at the start of every part build; upon detection of a faulty modeling base, the printer pauses and allows you to install a new one.

Powering On Dimension

Refer to “Powering On Dimension” on page 22 for instructions.

Powering Off Dimension

To power-off Dimension, move the power switch to the OFF position (see [Figure 6 on page 22](#)). You can do this at any time without harming the printer. No other steps are necessary. If this is done while the printer is building a part, the current build will be lost. System cooling fans will continue to operate for several minutes. This ensures a safe, systematic power down.

NOTE

For extended non-use periods, unload the material cartridges and then power off the system.

Cycling Power

Situations may occur that require the removal of all power to the Dimension system followed by a restart. This section discusses the procedure for this 'cycling' of the electrical system.

Cycle power:

1. Move the power switch to the OFF position (see [Figure 6 on page 22](#)). Wait for the printer to completely power down.
2. Move the circuit breaker located on the rear of the cabinet to the OFF (down) position.
3. Wait ten seconds and then move the circuit breaker to the ON (up) position.
4. Move the power switch to the ON position.
5. Wait for the system to prepare itself for normal operation.

NOTE

When the system is 'cycled' in this manner, it may take up to 15 minutes for it to reach its normal operating state.

Loading Material

Material cartridges are factory packaged in a box and an anti-static, moisture-proof bag to preserve shelf life. Material will stay humidity free inside the cartridge for at least 30 days after opening. Shelf life is more than one year if the cartridge package remains sealed.

Load material cartridges:

1. Remove packaging.
2. If present, remove the red sealing plug from the cartridge: (see [Figure 10](#))

NOTE

Plug must be removed before cartridge can be installed.

- A. Turn the plug a quarter turn counter clockwise.
- B. Lift up the plug to remove it from the cartridge - discard (or recycle) the plug.



Figure 10: Remove red plug before loading

3. Find the end of the material filament taped with a “flag”.

CAUTION



Be careful when touching the pinch roller on the side of the cartridge. If you roll it backwards, you could draw the material into the cartridge (see [Figure 11](#) for the correct direction to move the cartridge roller).

If this occurs, there is no way to retrieve the filament without opening the cartridge and exposing the material to humidity, which reduces shelf life to a few days.

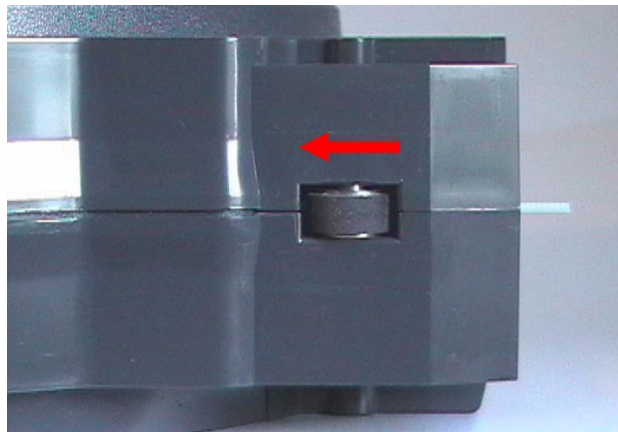

Figure 11: Direction to move cartridge roller

4. Pull filament out of cartridge to expose about 12 inches of material. You should easily be able to pull out the material.

NOTE

The above step makes sure that the filament will feed freely from the spool.

5. With the cutter from your Startup Kit, snip the filament flush with the end of the cartridge (see [Figure 12 on page 38](#)).

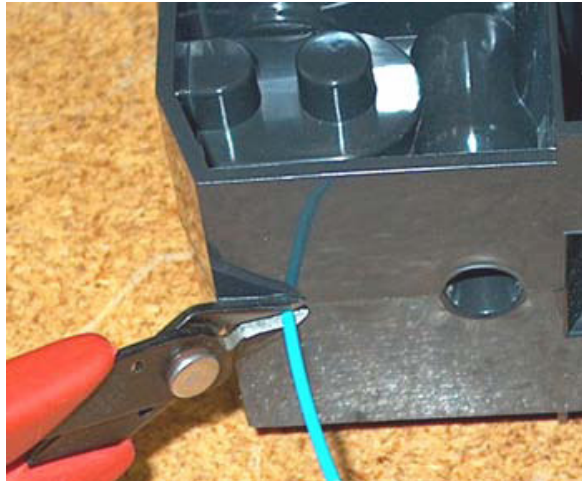

Figure 12: Snipping the material filament

6. If the printer is in **Idle**, press the **Material Load** button, which will be blinking.
7. Display will prompt with **Load Model - Replace Both Cartridges** (flashing)
8. Insert material cartridges into their appropriate slot from the front of the printer (Model material cartridge goes in the Top slot; Support material goes in the Bottom slot).

NOTE

You might get the message, Cartridge Not Replaced Or Invalid. This occurs if you do not insert the new cartridges within 30 seconds. In this case the cartridge will not lock into its slot. You must press the Retry button before continuing the process.

9. The panel will display **Load Material - Ready To Load**. Press **Load** to load material.
10. Watch the extrusion tips (see [Figure 13](#) on [page 39](#)) to see if material extrudes (purges) after loading. The panel will then display **Did Material Purge?**
 - Press **Yes** (to continue) or **No** (to return to Load Material) as appropriate — or press **Purge Again** if you're unsure which to choose.

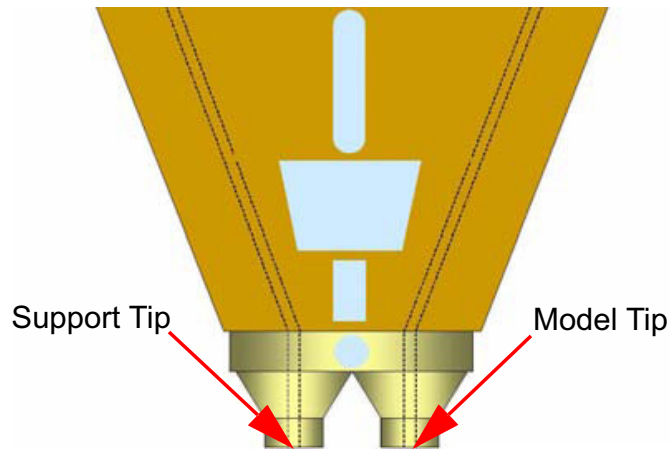

Figure 13: Close-up of extrusion tips

NOTE

If the display shows **Load Failed**, press **Retry**. If load fails again, remove the cartridge, snip the material (see [Figure 12](#) on [page 38](#)), remove filament in the printer, and reinsert the cartridge.

Unloading Material

The model and support material cartridges may be replaced separately or at the same time. In idle-, load-, or build-related modes, the panel displays the percentage of material remaining in the cartridges. If the printer will be operating unattended for a long period, and the material level is getting low, you may want to replace the cartridges before starting a new part. Of course, you will also need to replace the cartridges when they are empty.

Unload material cartridges:

1. From **Idle** (or **Ready To Build**), Press **Material Load**.
 - A. The panel displays **Load Material** and prompts with, **Replace model?**
 - Press **Yes**. to unload the Model Material. The panel displays **Replacing model**,
 - Press **No** if you do not wish to unload the model material.

- B. The panel then prompts with, **Replace support?**
 - Press **Yes.** to unload the Support Material.
The panel displays **Replacing support,**
 - Press **No** if you do not wish to unload the support material.
 - C. After you have made the above choices, the panel displays **Unloading** for approximately 60 to 75 seconds (the selected materials will be unloaded from the extrusion head).
 - D. When unloading is complete, the panel will prompt you to remove a cartridge based upon your choices - i.e., **Replace Both Cartridges, Replace Model (Top) Cartridge, or Replace Support (Bottom) Cartridge.**
2. Remove the material cartridge(s) by first pushing it forward gently, and then pulling it out of the slot.

CAUTION



Do NOT try to rewind the filament that remains in the system. This will cause material to cross-wind in the cartridge causing cartridge failure.

- When you remove a cartridge there will be approximately 180 cm (6 feet) of filament that will need to be pulled from the system. (This is normal. Material is only retracted from the extrusion head during 'unloading'.)
3. To store a partially used cartridge, place a small flag of tape on the filament near the cartridge. Cut off and discard the remaining material. The tape flag ensures the filament does not retract into the cartridge.

Building a Test Part

Factory test parts have been preloaded into your Dimension. To familiarize yourself with the system, it is recommended that you build one of the test parts before attempting to build one of your own files .

Once the printer has warmed up, material has been loaded, and a modeling base is in place, you can send a test part to the printer.

Build a test part:

1. Press **Maintenance**.
2. Press **Test Parts**, and select one of the available sample parts.

Dimension automatically starts building the part.

3. When the part is finished, follow the steps under [Removing a Completed Part](#) on [page 45](#).

Sending Your CAD File to the System

This section describes the procedures used for sending your own CAD files to Dimension.

Send a “job” to Dimension:

1. Create an STL file with your CAD software.
2. Click on the CatalystEX icon  on the desktop of your PC. The CatalystEX main window opens ([Figure 14 on page 42](#)).

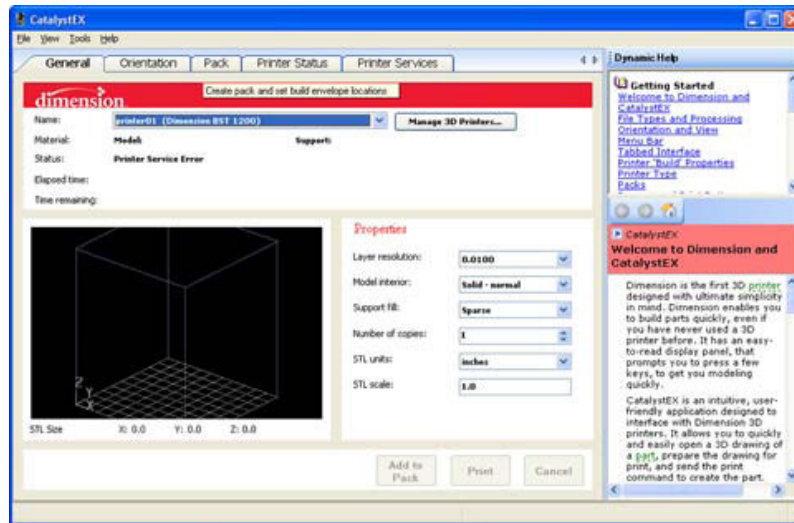

Figure 14: CatalystEX main window

3. From the **File** menu, click **Open**.
4. Select and Open an STL file produced with your CAD software.
5. Choose one of several options for printing your part. From the General Tab:

NOTE

For detailed information about the many file processing options available in CatalystEX, refer to the CatalystEX Help files.

- Click 'Print' to have CatalystEX process your part and immediately send it to your Dimension for printing.
...OR...
- Click 'Pack' to have CatalystEX process the part for printing, but not send the part to your Dimension... send the part to the printer later as part of a pack (from the Pack Tab).

Regardless of how you choose to prepare your file for printing, the end result will be the same. CatalystEX will process the STL file into a CMB file. It is the CMB file that CatalystEX will send to the Dimension printer to create your part.

NOTE

For more information about STL files, CMB files, part orientation, modeling envelope placement, print 'job' efficiency, and other print controls refer to the CatalystEX Help file.

Building a Part from Your File

After CatalystEX sends the CMB file to the printer, the panel displays **Ready to Build** along with your file's name.

Build a part:

Press **Start Model**. The system will warm up to correct build temperatures. After warm-up, the panel displays **Finding Home**, (the extrusion head is currently finding the top of the modeling base on which the part is to be built). After finding its starting point, Dimension begins building the part.

Read the display panel while building:

The top two lines of the display panel show printer-status messages (see [Figure 15](#)). The bottom line of the panel shows the material amounts remaining in the cartridges.

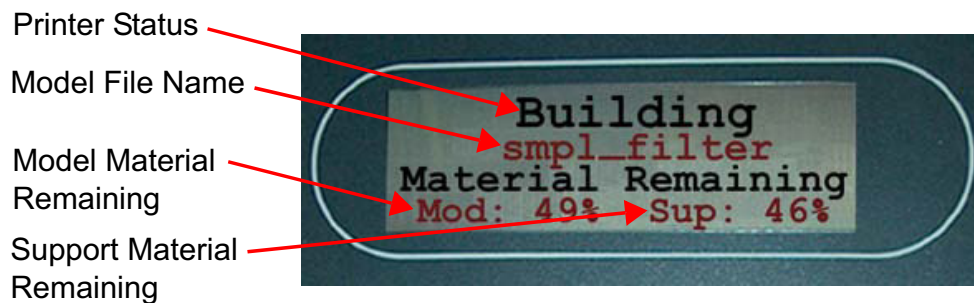

Figure 15: Display panel during build

Chamber Lights

When a part starts to build, the chamber lights are automatically ON. You can toggle lights ON or OFF through the Display Panel.

You can also turn the light on continuously. Go to the **Idle** or **Ready to Build** mode. Press **Maintenance** and then press **Next** until **Setup Maintenance** is displayed. Press **Lights Always**. The light will remain ON until the system is powered OFF.

Pausing Build

While building a part, you may want to pause the operation - e.g, to allow for replacement of a material cartridge. To pause the build operation at any time, press **Pause**.

NOTE

When the build process is paused, Dimension completes the current tool path before pausing.

Resuming Build from Pause Mode

If you have pressed **Pause**, and are ready to resume building the part, press **Resume**. Dimension resumes modeling.

Resuming Operations from Standby Mode

After several minutes of inactivity, Dimension enters Standby mode. During Standby, the head temperature will decrease to save energy.

Continue operation from Standby mode:

1. Press **Resume**.
 - The panel displays **Ready to Build** and your part's name (if there is a part in the queue). It also shows the amount of material remaining in the model material cartridge and the support material cartridge (e.g. **Mod 90 %**, **Sup 85 %**).
 - **Start Model** begins blinking.
2. Press **Start Model** to begin modeling.
(Dimension may require a few minutes to warm up to proper build temperatures. You can view the temperature values in the display.)

Canceling a Job

You can cancel a job at any time while the part is building.

Cancel a job:

1. Press **Pause**.
2. Once Dimension stops building, press **Cancel Build**. The panel displays **Are you Sure?**
3. Press **Yes**. The panel displays **Build Stopped** followed by the part name.
4. The panel prompts you to remove the part and replace the modeling base (See [“Inserting a Modeling Base” on page 34.](#)). Once the chamber door has been opened and closed, the panel asks: **Part Removed?**
5. Press **Yes** *only after* removing the part - refer to [“Removing a Completed Part”](#).

CAUTION



If you press **Yes** before removing the part, the system can be damaged, and a service call will be required.

Removing a Completed Part

When the part has completed, the panel displays **Completed Build**, and the file's name. It also shows **Remove Part** and **Replace Modeling Base**.

Remove a completed part from the Dimension system:

1. Open the modeling chamber door.
2. Release the modeling base retainers and pull the modeling base towards you, out of the tray guides.
3. Insert a new modeling base.
4. Close the modeling chamber door.

5. After you have opened and closed the door, the panel displays **Part Removed?** *only* after removing the part, press **Yes**.

CAUTION



The system can be damaged if you answer **Yes** and the part has not been removed!

- After you press **Yes**, the panel displays the status as **Ready to Build** for the next part in the queue.

Remove a completed part from the modeling base:

1. After removing the base from the printer, firmly flex the modeling base back and forth with your hands to loosen the part. For best results, flex the modeling base front-right to back-left.
2. Pull the part off the base or use a putty knife to pry the part completely off.

NOTE

Supports are much easier to remove when the modeling base is still warm.

Removing Support Material

Breakaway Supports

WARNING



Wear safety goggles and LEATHER gloves (provided in Startup Kit) when removing breakaway supports.

Dimension BST 768 uses breakaway supports. Removing breakaway support is a simple matter of gently removing material by scraping, or twisting. Basic tools such as a pick or needle-nose pliers can facilitate material removal from cavities.

Soluble Supports



WARNING

Wear safety goggles and safety gloves (provided in Startup Kit) when removing soluble supports.

When removing soluble supports *by hand*, wear LEATHER gloves.

When removing soluble supports *with the soluble concentrate*, wear RUBBER gloves.

Dimension SST printers (SST 768 and Elite) use soluble supports - a water-based solution designed to allow you to simply wash away the support material. Your part is left smooth and clean with the fine details intact. The soluble support material can be removed by hand with relative ease, but is designed to be dissolved off of your parts for hands-free part finishing.

Refer to the 'Soluble Support Technology (SST) Process Guide' for details regarding the removal of soluble support material.

Maintenance

Follow the simple procedures within this chapter to ensure continued proper operation of Dimension.

Startup Kit Tools

The Dimension Startup Kit contains replacement parts and a set of tools used to help you maintain the system. The following is a list of the tools contained in the Startup Kit.

- Needle Nose Pliers
- Allen Wrench Set
- Leather Insulated Gloves (Pair)
- Putty Knife
- Cutters
- Soft-bristled Glue Brush
- Brush (bronze)
- #2 Phillips Head Screwdriver
- Tube Anti-Seize Compound (SST 768 and Elite Only)

WARNING



**Krytox grease can cause skin irritation.
Avoid contact with skin and clothing
when it is being handled.**

- 2 oz. Tube Krytox Grease

After Each Build

Empty Purge Container

The black, plastic purge container is attached to the right side of the modeling envelope rear wall (see [Figure 1](#) on [page 12](#)).

NOTE

A full purge container may impact part quality.

1. Remove the purge container by grasping it and pushing it upward to release it from its three mounts.
2. Pull the container towards you and out of the chamber.

CAUTION



When reinstalling the container, make sure that it locks on all three mounts and hangs flush with the chamber wall to avoid damage.

3. Empty the container and reinstall on 3 mounts.

500 Hour Maintenance

NOTE

For printer hours, refer to the CatalystEX 'Printer Services' tab - 'Printer Info' button.

Clean Fan Filter

To clean the fan filter:

1. Locate the lower fan on the rear panel of Dimension and remove the plastic frame (snaps on and off) that secures the fan filter.
2. Clean the filter with soap and water, and blot it dry.
3. Reassemble.

Tip Cleaning Assembly (Brush/Flicker Assembly)

(Refer to [Figure 16 on page 52](#)).

NOTE

The flicker should be replaced after 500 hours. It is only necessary to replace the brush after 2000 hours.

1. Completely power down Dimension. See "[Powering Off Dimension](#)" on [page 23](#).
2. Remove the purge container. See "[Dimension Front View](#)" on [page 12](#).
3. Remove the old flicker. - loosen the flicker attachment (rear) screws and pull up on the flicker.
4. Insert the new flicker and tighten the rear screws while gently pushing down on the flicker.

NOTE

The bottom of the material tip must hit in the top 75% of the flicker.

5. Remove the old tip cleaning brush by loosening the two mounting screws and pulling up on the brush.
6. Install the new tip cleaning brush, but do not tighten the mounting screws.
7. With a glove on your hand, move the head so that the tips are above the tip cleaning brush.
8. Adjust the tip cleaning assembly until the brush lightly touches the bottom of the Model Tip Shroud. Tighten the brush mounting screws to 12 in-lbs (1.356 Nm) of torque.

NOTE

Ideally, the top of the brush and the top of the flicker should be the same height. Brush height, however is more important to tip maintenance than the flicker height.

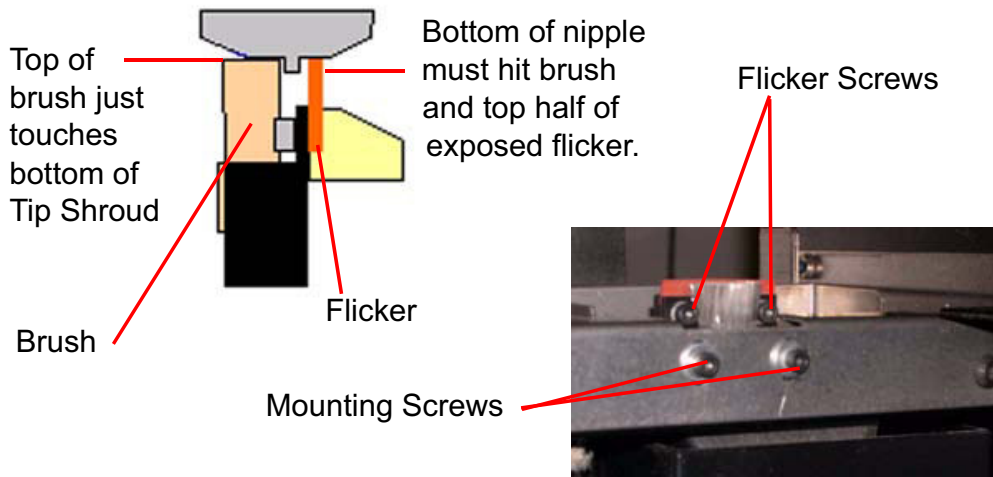

Figure 16: Replacing the tip cleaning brush

2000 Hour Maintenance

NOTE

For printer hours, refer to the CatalystEX 'Printer Services' tab - 'Printer Info' button.

Axis Maintenance

1. Clean and lubricate the Z-axis lead screw (*drive screw*), X-axis guide rods (2), Y-axis guide rods (2), and Z-axis guide rods (2). See [Figure 17](#) for locations.
 - Clean with isopropyl alcohol.

WARNING



Krytox grease can cause skin irritation. When it is being handled, use impervious gloves and avoid contact with skin and clothing.

- Lubricate using the Krytox grease provided in the Startup Kit. Use the grease sparingly.

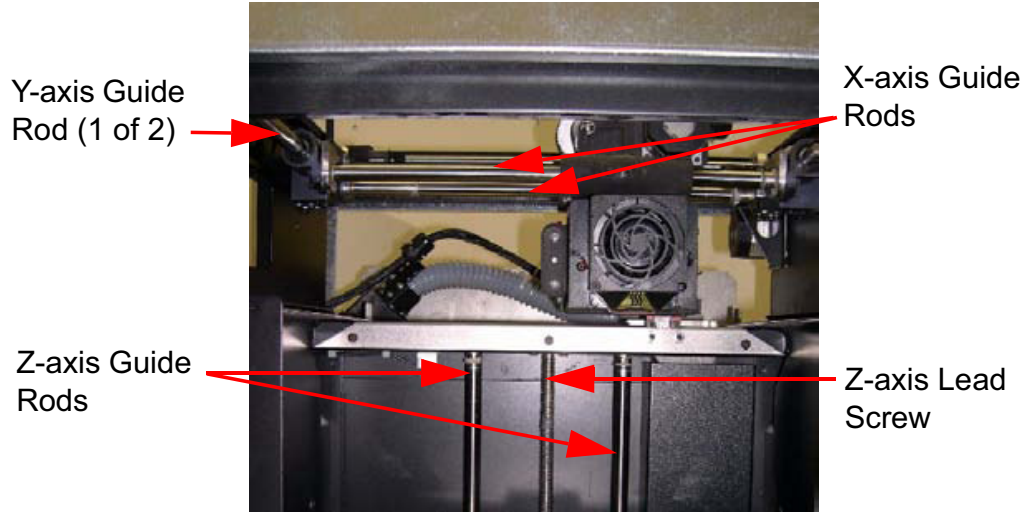

Figure 17: Lead Screw and Guide Rod Identification

As Needed Maintenance

The following maintenance items have no routine schedule but should be tended to as needed.

Remove Debris Buildup

Remove all material buildup on the Z Platform and around the lead screw (See [“Lead Screw and Guide Rod Identification” on page 53.](#)). Failure to do so could cause the base to become unlevel or the Z Platform to jam at its upper limit.

Vacuum Build Chamber

Vacuum the build chamber to remove all foreign particles and purged material.

Clean Door Glass

The door glass can be cleaned with any commercial glass cleaner.

Chamber Lamp Replacement

Replace the chamber lamp when it burns out.

NOTE

There are two chamber lamps in the modeling chamber. They are located on the front wall of the chamber. One to the upper right, the other to the upper left.

To replace the chamber lamp:

1. Power down the system.
2. Pull the lamp straight out of the socket.

CAUTION



Do not touch the new bulb with bare fingers. The natural oil of your skin can cause premature bulb failure. Grasp the base of the bulb instead.

Use only 24 V, 20 W bulbs.

3. Find the socket wires leading away from the socket.
4. Pull on the socket wires while inserting the two prongs of the new lamp into the two holes of the socket. When the lamp is seated into the socket, release the socket wires.

NOTE

Pulling on the socket wires releases the spring-loaded contacts in the socket. If the lamp is installed without pulling on the socket wires, the lamp might not be held securely in the socket.

Tip Shroud Replacement - SST 768 and Elite Only

Due to repeated contact with the tip-wipe brush, it is normal for the tip shroud to become worn. When chronic build up of material around the tip area or clumps of burnt material become imbedded in the part, replace the tip shroud.

WARNING



Head area is very hot! Use gloves when installing a new shroud!

1. Enter **Maintenance**, press **Next**, and access the **Table Maintenance** function.

The head temperature decreases.

2. Using a 1/8-inch hex wrench, back out the two head-plate mounting screws approximately 1/8 inch (see [Figure 18](#)). Do not remove the screws.
3. Pull the head plate slightly away from the head until the right side of the plate is clear of the mounting screw head.
4. Pivot the right side of the head plate upwards, and rest the right side of the plate on the right mounting screw, as shown in [Figure 18](#). There is a small notch on the bottom of the plate for this purpose.

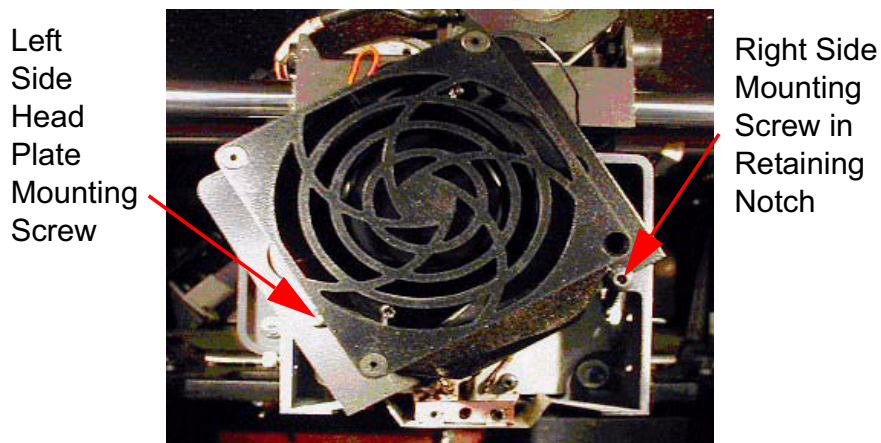

Figure 18: Head plate in shroud replacement position

5. Locate the shroud, the shroud-mounting screws, and shield, as shown in [Figure 19](#).

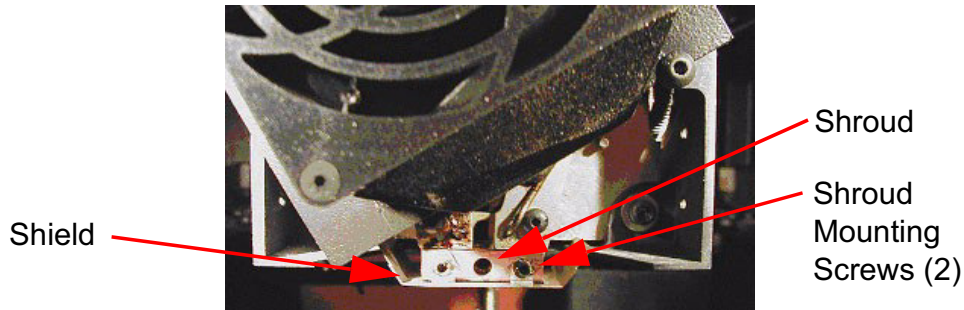

Figure 19: Shroud and shield location

6. Remove the two shroud mounting screws using a 3/32 inch hex wrench.

WARNING



Screws are very hot!! Use gloves when working in this area of printer!

7. Once the screws are removed, pull the metal shield down to remove. Be careful not to bend or damage the shield.
8. Pull the shroud downward to remove it.
9. Clean the exposed tip with the bronze brush provided in the Startup Kit.
10. Install the new shroud by pushing it up onto the tip.

NOTE

The shroud is keyed and can only be installed with the holes offset to the rear.

11. Slide the metal shield back over the shroud.
12. Check that both the shroud and shield are positioned correctly.

NOTE

Apply a thin coat of anti-seize compound to the threads of the shroud mounting screws.

13. Drive the two shroud-mounting screws into the shroud and tighten, but **do not over-tighten the screws!**

14. Lower the head cover into position, and tighten both head cover screws.
15. Exit the Table Maintenance function.
16. Build a test part to verify system is operating correctly. See ["Building a Test Part"](#) on [page 41](#).

Troubleshooting

Troubleshooting Checklist

Problem or error message	Solution
No power	Verify power cord is securely plugged in.
	Verify that the circuit breaker (at rear of system) and the power switch (on right panel of system) are both in the ON position.
	Verify AC power is present at wall outlet.
System fails to reach operating temperatures	Verify the system is not connected to an extension cord or power strip.
Material not extruding	Filament may be jammed in extrusion head (see “Loss of Extrusion” on page 61).
Purge material accumulating on part.	Make sure that the flicker and brush are set to the proper height. (See “Tip Cleaning Assembly (Brush/Flicker Assembly)” on page 51 .)
	Check condition of Flicker and Brush. Replace if worn. (See “Tip Cleaning Assembly (Brush/Flicker Assembly)” on page 51 .)
No text displayed on Display Panel	Cycle power (see “Cycling Power” on page 35).
Cannot communicate with system through network	Make sure network cables are connected - at the printer, at the PC, and where cables connect to network boxes.
	Re-configure settings per (see “Networking Your Printer” on page 25).

60 Troubleshooting

Problem or error message	Solution
Cannot communicate with system through network (Continued.)	If using a Static network address, verify that the IP address entered in CatalystEX has the same value as the address entered for the printer.
	Your system configuration may have changed. Contact your Network Administrator.
Error Code displayed on Display Panel	Call your local reseller for customer service. For more information, refer to “Fault Determination Codes” on page 61 .
Display Panel displays Build Error	Partial or bad part file sent to system. Check STL file validity in CAD software; reprocess STL in CatalystEX and redownload to system.
Display Panel displays Can't Find Home - Check Modeling Base	Verify a modeling base is inserted.
	Modeling base may be used or defective – replace.
Display Panel displays Communication lost at HR:MN UCT	The system stopped reporting its status at the Universal Coordinated Time (UCT) shown. Wait for the system to complete building the part. The system will automatically restart and display Build Complete. It is then safe to remove the model.
Display Panel displays Could Not Read Cartridge	Remove cartridge and cycle power (see “Cycling Power” on page 35); reload cartridge.
	Try a different cartridge.
Display Panel displays Load Failed	Retry with same cartridge.
	Try a different cartridge.
	Filament may be jammed in extrusion head (see “Loss of Extrusion” on page 61).

Fault Determination Codes

If a fault occurs, which would prevent Dimension from executing an operator request, the system will begin to shut down and cool. The panel will display one or two error codes. An error-code list (with the filename “error.txt”) can be found on the CD-ROM for the controller software. (Because this list may change with each new software version, make sure to use your most recent version of the controller software on CD-ROM).

After the printer has finished cooling, the only option displayed is **Continue**. Press **Continue** and the printer reboots and tries to return to normal operation. If pressing **Continue** does not recover the printer, the printer should be power cycled (see “[Cycling Power](#)” on page 35); wait 60 seconds before switching power on again. In most cases you will be able to continue operation. However, if the printer continues to shut down and display the same error, call your service representative.

Loss of Extrusion

Diagnosing Loss of Extrusion

Occasionally, the printer’s head may experience loss of extrusion. This will be evident by observing one of the following:

- Seeing the head moving with no material coming out of either liquefier tip
- The height of the model and support materials are not equal
- Sagging structures due to lack of support materials

WARNING



The head area is very hot!! Use gloves when working in this area of printer!

Diagnose loss of extrusion:

1. Press **Cancel** and remove any parts from the printer.

2. Insert a new modeling base.
3. From **Idle**, enter **Head Maintenance**
 - A. Using the keypad, press **Maintenance**.
 - B. Press **Next**. The head will come to rest in the center of the chamber and the Z Platform will change position. Choose **Head Maintenance**.
4. Determine if there is an extrusion problem by pressing **Forward** (command will be available after Head reaches operating temperature). Watch both tips for several seconds, looking for extrusion (material purge).

NOTE

If it was previously at a cool temperature, the tip may not immediately extrude material. After the tip reaches operating temperature you may need to wait up to 30 seconds before extrusion will begin.

5. Press **Stop** to stop the extrusion.
6. If material steadily flowed from the tips, the head is not experiencing loss of extrusion.
7. Return the printer to the Maintenance state - Push **Done**, then answer **Yes** when the printer displays **Is Material Loaded?**
8. If material did not extrude from both tips follow the procedure in the following section, "[Recovering From Loss of Extrusion](#)".

Recovering From Loss of Extrusion

NOTE

It is recommended that you read and understand this entire procedure before performing any of the work.

1. Enter **Head Maintenance** mode.
 - From **Idle**, press **Maintenance** > then **Next** > then **Head Maintenance**.

WARNING



The head area is very hot!! Use leather gloves when working in this area of printer!

2. With the Phillips-head screwdriver provided in the Startup Kit, release the two screws securing the head assembly (see [Figure 20](#) - the screws require only $\frac{1}{4}$ turn to release). Swing open the front half of the head.

NOTE

You may feel resistance when you swing open the front half of the head. One, or both, of the material filament lines are likely to still be routed into the head and held by the drive motor. This is normal. Swing the door open slowly, but firmly.

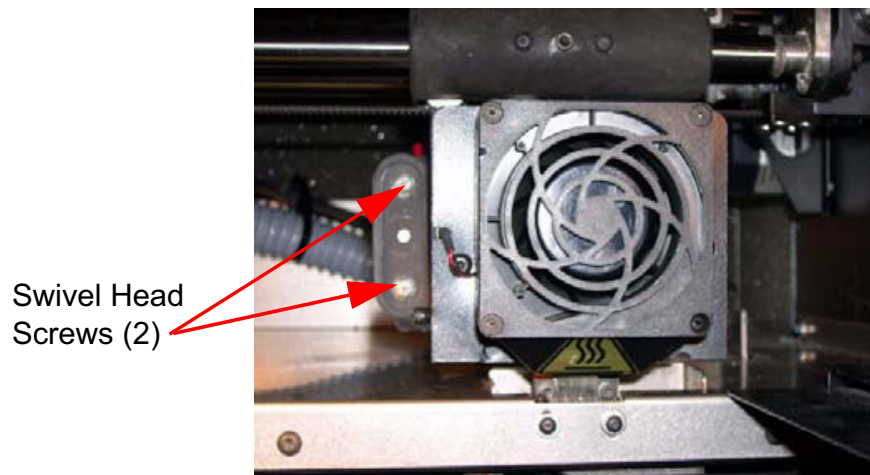

*Figure 20: Location of swivel head screws (2)
(Head shown is SST 768 & Elite - Screw location is the same for BST 768)*

3. Attempt to re-establish extrusion.

NOTE

Both material filaments must be coming out of the feed tubes at the back of the head (see [Figure 21](#)) and still be going into the drive block funnels in the front half of the head in order to proceed with this step. If not, skip to step 4.

- A. Run both filament motors forward while gently pushing the filament that stopped extruding into the filament guide rollers. Do so for about three seconds.

- B. If the purge was successful:
- i. Continue to run both filament motors forward and slowly swivel the head closed. Be careful to not pinch the filament or the head wiring when closing the head.
 - ii. Once the head is closed, tighten both of the swivel head screws, $\frac{1}{4}$ turn.
 - iii. Verify material continues to extrude through both tips for an additional 30 seconds, then press **Stop** to halt extrusion.
 - iv. Push **Done**. The panel displays **Is material loaded?**
 - v. Press **Yes**. The panel displays **Exiting maintenance** and you can now resume normal operation. (Skip Steps 4 through 13.)
- C. If material did not purge, continue with the following steps.
4. Snip both filaments approximately 1 inch from the fixed part of the head (see [Figure 21](#)).

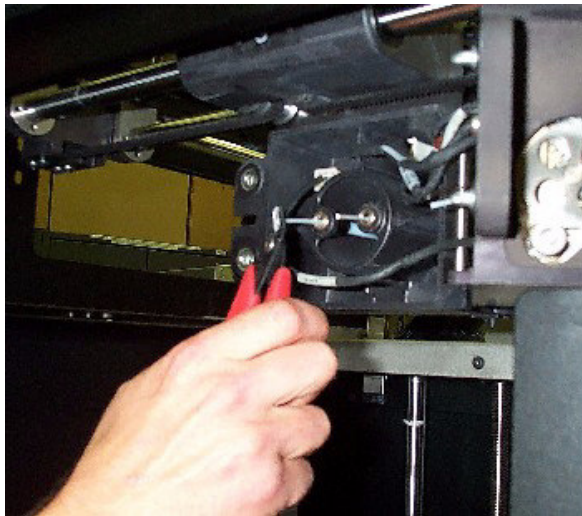

Figure 21: Materials coming out of feed tubes

NOTE

On rare occasions, the material may NOT be extending out from the feed tubes. If this occurs, push in the appropriate cartridge to unlatch it. Pull out the cartridge to expose the filament and manually feed the filament through the feed tubes until the

filament comes through the back of the head. Pull the filament from the head while inserting the cartridge. Once the cartridge latches, pull an additional 6 inches of filament through the head (to make sure the filament is not caught at the cartridge receiver). Then snip the filament approximately 1 inch from the fixed part of the head.

5. Remove the filament from both drive block assemblies if there is enough to remove by hand.
 - A. Select **Reverse**.

This causes the drive wheels to reverse, so the material filaments can be backed out of the liquefier.
 - B. Grasp the filament from the drive blocks with your fingertips, and gently pull it out of the drive wheels. Repeat for second filament. If you are unable to easily remove either filament, leave the filament in the drive block for now.
6. Remove both drive block assemblies from the swivel part of the head.
 - A. Set a material cartridge on top of the tray to support the removed drive block assemblies.
 - B. Remove the support drive block first. Use a 7/64" Allen wrench to remove the two screws securing the motor assembly as shown in [Figure 22](#).

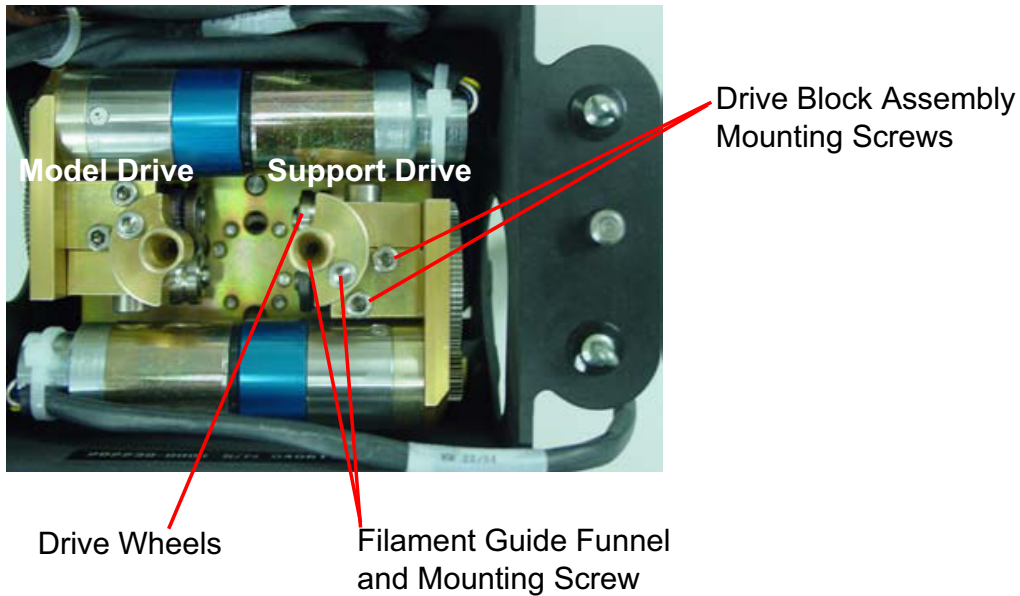

Figure 22: Removing the drive block assemblies to check for buildup

- C. Set the drive block assembly on the material cartridge.
- D. Remove the model drive block assembly the same way.
7. With the drive blocks removed, look through both filament guide funnels for obstructions. If an obstruction is present, clear the drive block obstruction:
 - A. Remove the filament guide funnel.
Use the 7/64" Allen wrench provided in the Startup Kit to remove the filament-guide mounting screw as shown in [Figure 22](#).
 - B. Remove any excess material; use the needle-nose pliers if necessary.
 - C. Replace the filament guide funnel.

CAUTION



Liquefier inlet tubes are fragile. Be careful not to damage them when removing material.

8. With the drive blocks removed, inspect liquefier tube inlet area.
 - A. (For **BST 768**) Inspect the liquefier inlet tubes (see [Figure 23](#)).
 - i. If material is extended out from an inlet tube, gently remove material with the bronze brush or needle-nose pliers.
 - ii. Inspect for damage to the inlet tube.

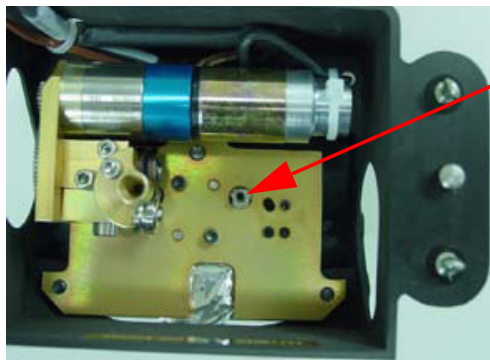

BST 768 Support Liquefier Inlet Tube

(shown with only the support drive block removed)

BST 768 Model Liquefier Inlet Tube will look the same.

Figure 23: BST 768 - Inspecting the liquefier inlet tubes

- B. (For **SST 768 and Elite**) Inspect the *model* liquefier inlet tube, and the *support inlet funnel* covering the *support* liquefier inlet tube (see [Figure 24](#)).
 - i. If material is extended out from the *inlet* tube:
 - a. Gently remove material with the bronze brush or needle-nose pliers, if necessary.
 - b. Inspect for damage to the inlet tube.
 - i. If material is extended out from the *support* inlet funnel:
 - a. Gently remove material with the bronze brush or needle-nose pliers, if necessary.
 - b. If the material buildup in the inlet funnel is difficult to remove, insert a 1/16" Allen wrench into the liquefier inlet funnel and try pushing the obstruction forward.

- c. If this doesn't work, remove the liquefier inlet funnel using a 1/4" nut driver. Dissolve support material from the funnel with the soluble support solution.

NOTE

It is typical for material to build up around the support liquefier inlet tube under the inlet funnel. Do not remove this material unless it interferes with reinstallation of the inlet funnel.

- d. Inspect for damage to the support inlet tube.
- e. Replace the liquefier inlet funnel.

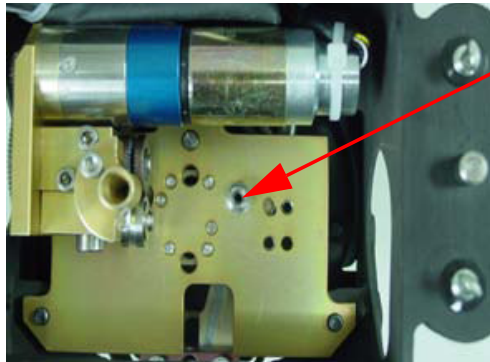

SST 768 & Elite Support Liquefier Inlet Funnel

(shown with only the support drive block removed)

SST 768 & Elite Model Liquefier Inlet Tube does not have a funnel.

Figure 24: SST 768 & Elite- Inspecting the support liquefier inlet funnel and model liquifier inl

9. Clean the inside of the liquefier inlet tubes. Carefully insert a 1/16" Allen wrench into the liquefier inlet tubes and gently push forward until it stops (about 1/4 inch).
10. Replace both drive-block assemblies. Install the model drive block assembly first. Make sure the block is seated flush against the swivel plate.

IMPORTANT



Be careful not to pinch the assembly's wiring harness under the block or behind the motor before replacing and tightening the mounting screws.

11. Repeat for the support drive block assembly.

12. Clean the drive wheels.
 - A. Press **Select Drive** repeatedly until the display shows **Both Drive Motors**.
 - B. Press **Reverse**.
 - C. With the glue brush provided in the Startup Kit, clear any material buildup from each drive by brushing its serrated drive wheel.

13. Check for Extrusion.
 - A. Press **Forward**.
Pull out 6 inches of material from the fixed head housing. Feed the filament into the drive blocks and look at the tips to verify material is extruding through both liquefiers.
 - B. If the filament does not extrude:
 - i. Stop the motors and return to Step 4.
 - ii. If, after two tries the material fails to extrude, call your service provider.

IMPORTANT



While closing the head, be careful not to crimp the filament, and make sure that the head wiring doesn't get pinched between the swivel head and the rear head housing.

- C. If the purge was successful, continue to run both filament motors forward and slowly swivel the head closed.
- D. Once the head is closed, tighten both ¼ turn screws.
- E. Verify material continues to extrude through both tips for an additional 30 seconds, and then press **Stop** to halt extrusion.
- F. Push **Done**. The panel displays **Is material loaded?**
- G. Press **Yes**. The panel displays **Exiting maintenance** and you can resume normal operation.



STRATASYS[®]

14950 Martin Drive
Eden Prairie, MN 55344 USA
Telephone: (952) 937-3000
Fax: (952) 937-0070
Web Site: www.dimensionprinting.com

Stratasys Document # **204400-0002**